



Job _____ Item No. _____

WELLS MODEL: HC-1006, HC-1256, & HC-2256 BUILT-IN CERAMIC HOTPLATES



HC-1006/1256



HC-2256

DESCRIPTION

Wells Ceramic Hotplates HC-1006, HC-1256, and HC-2256 are leaders in the hotplate industry because of their efficient and easy-to-use features. Heat-up is five times faster than conventional hotplates providing a clear advantage in commercial food preparation. The completely sealed ceramic surface resists spills and allows for easy cleanup.

WARRANTY

These units come with a one [1] year warranty for parts and labor.

CERTIFICATIONS



FEATURES

- **Heats five times faster** than any conventional hotplate, reducing cooking time and saving energy
- **Smooth, flat surface** works with any pot or skillet and is easy-to-clean.
- **Completely sealed, non-porous surface** resists thermal shock (quick, extreme temperature changes)
- **Long life, fast glowing, radiant element technology** provides even heating of cooking surface that is ideal for display cooking and specialty applications

ACCESSORIES/OPTIONS

Cordset, 30 AMP, 1ph, Nema 6-30P, 20141
(HC-1256 and HC-2256 only)



WELLS MANUFACTURING INTERNATIONAL INC.
265 Hobson Street • Smithville, Tennessee 37166
Telephone 800 264 7827 • www.wells-mfg.com

Printed in the U.S.A. • 2M-301125 REV D (10-23)
Specifications are subject to change without notice
and are not intended for installation purposes.



WELLS MODEL: HC-1006, HC-1256, & HC-2256 BUILT-IN CERAMIC HOTPLATES

MINIMUM CLEARANCE REQUIRED FROM ALL UNITS TO THE NEAREST SURFACE.			
BACK	SIDE	BOTTOM	FRONT
$\frac{1}{25}$	$\frac{1}{25}$	$\frac{5}{127}$	$\frac{3 \ 5/8}{92}$
(25)	(25)	(127)	(92)

EQUIPMENT DIMENSIONS: INCH [MM]

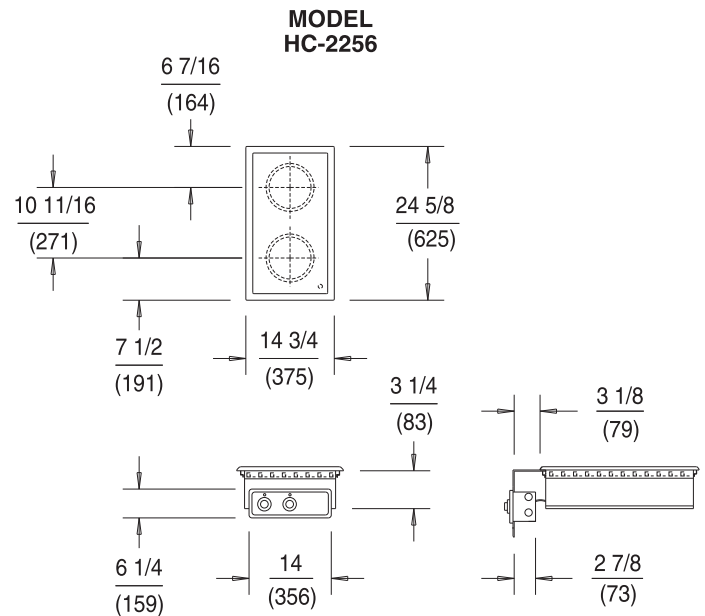
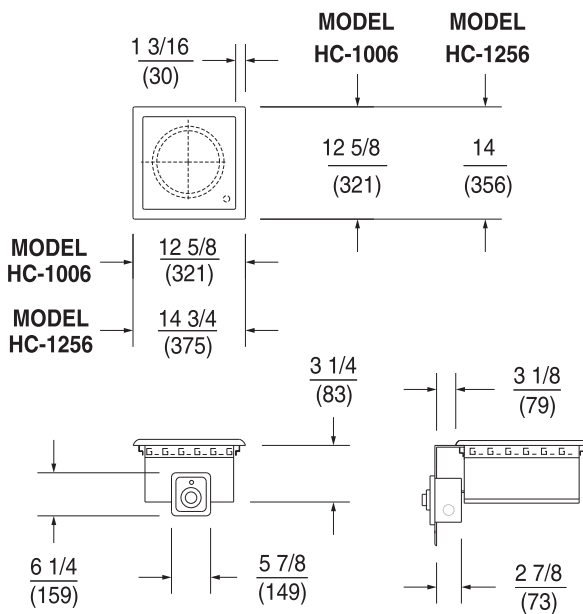

NOTE: Specifications are subject to change without notice and are not intended for installation purposes. See installation instructions prior to installing the unit.

SK3209 REV - (10-23)

MODEL	WIDTH in. (mm)	DEPTH in. (mm)	TEMP. SETTINGS	VOLTS	WATTS	AMPS PER LINE 3Ø			AMPS 1Ø	PLUG	APPROX. SHIP WEIGHT	APPROX. INSTALL WEIGHT
HC-1006	12.6 (321)	12.6 (321)	OFF/LO to HI	120	1400	-	-	-	11.7	N/A	15 lb. (7 kg)	12 lb. (5 kg)
HC-1256	14.8 (375)	14 (356)	OFF/LO to HI	208	1900	-	-	-	9.0	6-30P	16 lb. (7 kg)	13 lb (6 kg)
				240	2500	-	-	-	10.4	6-30P		
HC-1256EU	14.8 (375)	14 (356)	OFF/LO to HI	220-240	2500	-	-	-	10.4	SUPPLIED		
HC-2256	14.8 (375)	24.6 (625)	OFF/LO to HI	208	3800	15.6	9.0	9.0	18.1	6-30P	26 lb. (12 kg)	23 lb. (10 kg)
				240	5000	18.0	10.4	10.4	20.8	6-30P		

Due to periodic changes in designs, methods, procedures, policies and regulations, the specifications contained in this sheet are subject to change without notice. While Star Manufacturing exercises good faith efforts to provide information that is accurate, we are not responsible for errors or omissions in information provided or conclusions reached as a result of using the specifications. By using the information provided, the user assumes all risks in connection with such use.

